

Crestron GLS-OIR-C-450/1500
INFRARED CEILING MOUNTED
OCCUPANCY SENSOR
Operations & Installation Guide

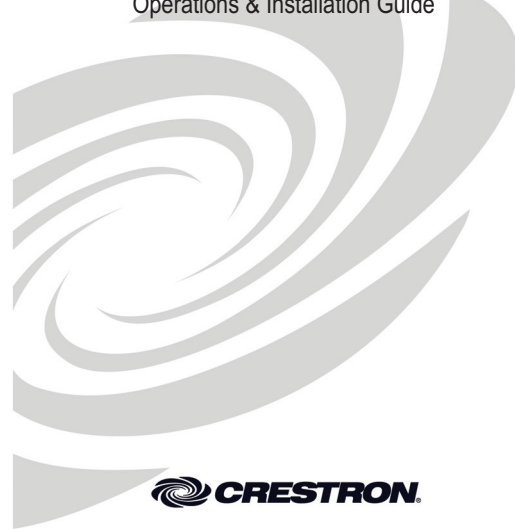

FCC Compliance Statement

This device complies with part 15 and part 18 of the FCC rules. Operation is subject to the following two conditions: (1) This device must not cause harmful interference, and (2) This device must accept any interference received, including interference that may cause undesired operation.

Further Inquiries

If you cannot locate specific information or have questions after reviewing this guide, please take advantage of Crestron's award winning customer service team by calling Crestron at 1-888-CRESTRON [1-888-273-7876].

You can also log onto the online help section of the Crestron website (www.crestron.com/onlinehelp) to ask questions about Crestron products. First-time users will need to establish a user account to fully benefit from all available features.

Future Updates

As Crestron improves functions, adds new features and extends the capabilities of the GLS-OIR-C units, additional information may be made available as manual updates. These updates are solely electronic and serve as intermediary supplements prior to the release of a complete technical documentation revision.

Check the Crestron website periodically for manual update availability and its relevance. Updates are identified as an "Addendum" in the Download column.

Crestron Electronics, Inc. **Operations & Installation Guide-DOC. 6770A**
 15 Volvo Drive Rockleigh, NJ 07647 (2023017)
 Tel: 888.CRESTRON 12.08
 Fax: 201.767.7576 Specifications subject to
 www.crestron.com change without notice.

WARNINGS, CAUTIONS & NOTES

WARNING: To avoid fire, shock, or death; turn off power at circuit breaker or fuse and test that power is off before wiring!

CAUTION: Insufficient power can lead to unpredictable results or damage to the equipment. Please use the Crestron Power Calculator to help calculate how much power is needed for the system. (www.crestron.com/calculators).

NOTES: Observe the following points regarding sensor installation.

- To be installed and/or used in accordance with appropriate electrical codes and regulations.
- If you are unsure about any part of these instructions, consult a qualified electrician.
- Sensors must be mounted on a vibration free surface.
- All sensors must be mounted at least 6 feet away from air vents.
- Do not mount sensors closer than 10 feet from each other.
- Do not touch the inner surface of the lens. Clean outer surface with a damp cloth only.

NETWORK WIRING

When wiring the Cresnet® network, consider the following:

- Use Crestron Certified Wire.
- Use Crestron power supplies for Crestron equipment.
- Provide sufficient power to the system.

PREPARING AND CONNECTING WIRES

Strip the ends of the wires approximately 1/2". Use care to avoid nicking the conductors. Twist together the ends of the wires that share a connection and tin the twisted connection. Apply solder only to the ends of the twisted wires. Avoid tinning too far up the wires or the end becomes brittle.

DESCRIPTION

The Occupancy Sensor is a low-voltage infrared sensor that works with the GLS-SIM (or other compatible interface) to automatically control lighting. The exact behavior of the sensor can be configured via software, but the sensor is typically used to turn lights on when a room or area is occupied, and to shut them off when the room or area is vacated. The sensor continually analyzes and adjusts to changing conditions. The sensor uses the latest microprocessor-based technology which permits it to continually adjust and optimize its performance. Infrared motion detection gives higher false triggering immunity that yields a sensor with excellent performance.

Model/Feature Basics

Model No.	Description	Current Consumption	Coverage	Suggested Mounting Location
GLS-OIR-C-450	High Density	20mA	450sq. ft	Mount in corner/over doorway
GLS-OIR-C-1500	Extended Range	20mA	1500 sq. ft.	Mount in center of room/area

INSTALLATION INSTRUCTIONS

These instructions include three typical installation options (A, B, and C). Choose one that best suits your needs. Other methods may be possible but they are not described here.

Parts Supplied

Sensor (1)	Threaded Rod (1) and Hex nut (1)
#8-32 x 1/2" screw (2)	Half Mask (1)
#8-32 x 1-1/2" screw (2)	360° Perforated Mask (1)
#8x32 Washer and Nut (2)	Plastic Washer (1)

Tools/Equipment Required (not supplied)

Slotted/Phillips Screwdriver	Electrical Tape
Pliers	Pencil
Diagonal Cutters	

1. Select the location for mounting the sensor and proper masking for your application. (Refer to Mounting/Masking Location Diagram).
2. Use the supplied threaded rod or other means to make a hole (1/2" to 1") in the ceiling tile just large enough to pass the shaft of the threaded rod through.
3. Insert the sensor wires through the flared end of the threaded rod. Position the threaded rod to the base of the sensor.
4. Insert the flared end of the threaded rod into the opening in the bottom of the sensor and twist to lock into place.
5. Push the wires into the hole in the ceiling tile and insert the threaded rod until the sensor is flush with the tile.
6. Insert wires through the hole in the included washer, then place the washer over the rod and secure in position using the included hex nut.
7. Connect low voltage wires from the GLS-SIM or other Crestron® device as shown in the wiring diagram. Twist strands of each lead tightly and, with circuit conductors, push firmly into appropriate wire connector. Screw connectors on clockwise making sure that no bare conductor shows below the wire connectors. Secure each connector with electrical tape.
8. Rotate the sensor to the desired orientation. Note that the sensor base and backcover are keyed. To lock the device in place, ensure that the arrows are not aligned.
9. Restore power at circuit breaker or fuse. INSTALLATION IS COMPLETE.

Mounting to Drop Ceiling Using Threaded Rod

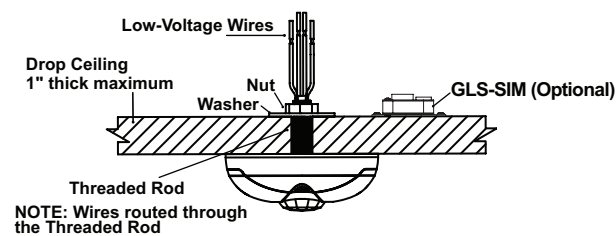

OPTION B. Drop Ceiling Installation Using Screws

NOTE: You may use the mounting screws, nuts and washers included, or screws in combination with commercially available wall anchors.

1. Select the location for mounting of the sensor and proper masking for your application. (Refer to Mounting/Masking Location Diagram.)
2. Make a hole in the ceiling tile large enough to pass the wire connections and wire nuts through (approximately 1" diameter).
3. Remove the back cover of the sensor. Hold the back cover and body of the sensor and rotate until the two arrows line up, and pull them apart.
4. Install back cover of the ceiling sensor to the wallboard or drop ceiling using the included screws, nuts and washers, or screws in combination with commercially available wall anchors.

OPTION B. Drop Ceiling Installation Using Screws (Cont'd)

5. Connect low voltage wires from the GLS-SIM or other Crestron device as shown in the wiring diagram. Twist strands of each lead tightly and, with circuit conductors, push firmly into appropriate wire connector. Screw connectors on clockwise making sure that no bare conductor shows below the wire connectors. Secure each connector with electrical tape.
6. Push wire connections through the center hole of the back cover and into the ceiling.
7. Secure the sensor body to the back cover by aligning the arrows. Lock it by turning the sensor such that the arrows do not line up.
8. Rotate the sensor to the desired orientation.
9. Restore power at the circuit breaker or fuse. INSTALLATION IS COMPLETE.

Mounting to Drop Ceiling Using Screws

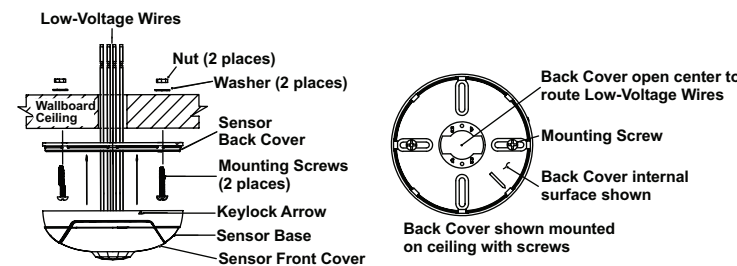

OPTION C. Back Box or Surface Mount Raceway Installation

1. Select the location for mounting of the sensor and proper masking for your application (Refer to Mounting/Masking Location Diagram).
2. Refer to the suggested mounting option illustrations below.

Mounting to Octagon Back Box Installed Flush to Drop Ceiling

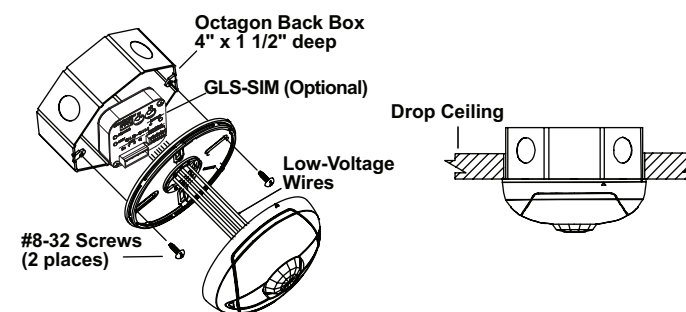

Mounting to Round Fixture with Raceway for Wallboard Ceiling Installation

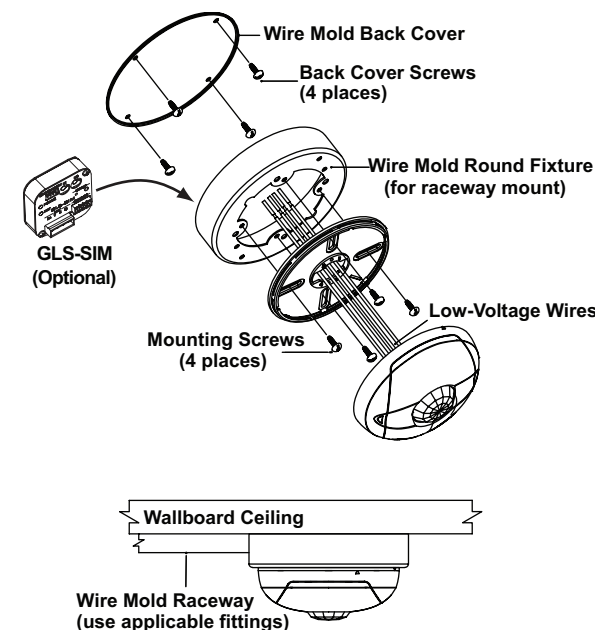

MOUNTING/MASKING LOCATION DIAGRAM

The supplied masks mount in the sensor front cover. The half mask is supplied pre-mounted to demonstrate the mounting method. The perforated mask has twelve 30° removable segments that allow you to mask particular areas to prevent undesirable triggers from affecting the sensor operation. The following illustrations provide typical application examples.

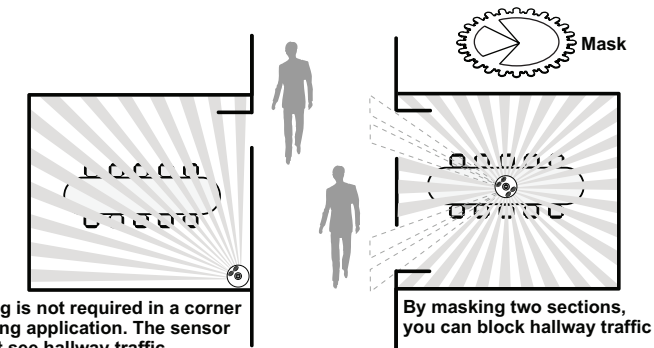

TYPICAL APPLICATION DIAGRAMS

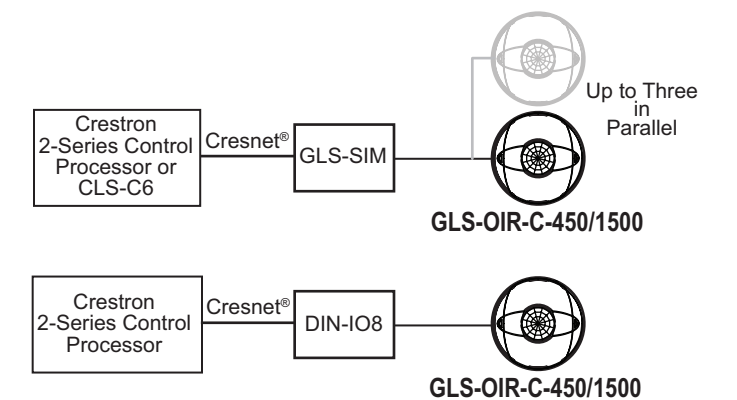

WIRING DIAGRAMS

Connecting Sensors to the GLS-SIM

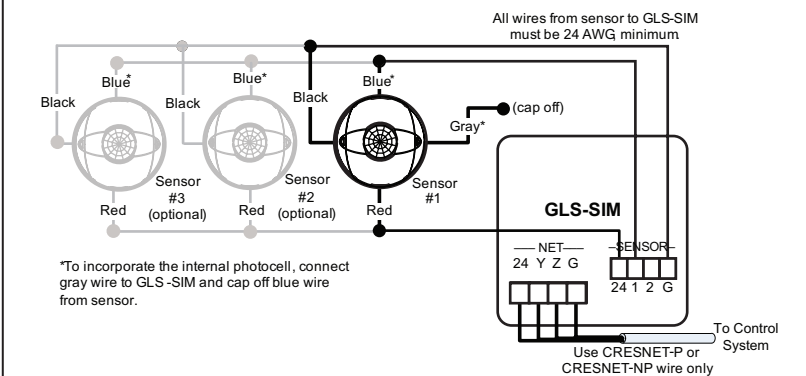

Connecting Sensors to the DIN-IO8 or Equivalent**

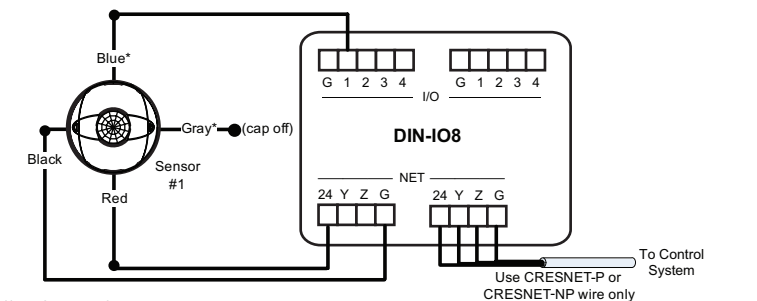

**The following Crestron devices may be used to integrate the sensors into a Cresnet system by following the schematic shown here:

DIN-IO8	DIN-AP2	PAC2	PRO2
AV2	CP2E	MP2E	CNXIO16

Any Crestron product with Versiports

NOTE: The same Crestron power supply MUST be used to power both the sensors and the interface device (e.g., DIN-IO8). Otherwise, there is a risk of damage to the interface device.

*To incorporate the internal photocell, connect the gray wire to the DIN-IO8 (or other interface device) and cap off the blue wire from the sensor.

OPERATION

The descriptions below refer to a system which has been configured to turn the lights on when a room or area is occupied, and turn them off when the room or area is vacated.

- Delayed-Off Time.** The sensor is designed to turn the lights off if no motion is detected after a specified time. This length of time is called the delayed-off time and is set using the timer (black) knob on the sensor. The adapting patterns will modify the delayed-off time to fit the parameters of each installation based on environmental conditions and occupancy patterns.
- Walk-through Mode.** The walk-through feature is useful when a room is momentarily occupied. With this feature, the sensor will turn the lights off shortly after the person leaves the room. The walk-through feature works as follows: When a person enters the room, the lights will turn on. If the person leaves the room before the default walk-through time-out of 2.5 minutes, the sensor will turn the lights off. If the person stays in the room for longer than 2.5 minutes, the sensor will proceed to the *Occupied* mode.
- LED Operation.** There are two LED indicators that will flash when motion is detected. The LED flash can be disabled using the LED disable switch setting. Green flash indicates motion detection by ultrasonic technology. Red flash indicates motion detection by infrared technology.

ADAPTIVE FUNCTIONS

The sensor continually analyzes the parameters of the motion detection signal and adjusts its internal operation to maximize detection of motion while minimizing the effects of noise (electrical noise, air currents, temperature changes, etc.).

Operation

When the lights turn on, the sensor initially starts the *Walk-through* mode. Once the room is occupied for longer than 2.5 minutes, the sensor ends the *Walk-through* mode and begins the *Occupied* mode. When the sensor is first installed, the delayed-off time for the *Occupied* mode is based on the time adjustment settings. While the sensor is in use, the delayed-off time will change, based on how the sensor adapts to the room conditions. Whenever the sensor subsequently turns on, the value of the delayed-off time will be the *adapted* value (refer to Occupancy Pattern Learning For Delayed Off Time).

The adapted settings can be reset using the DIP switch.

Occupancy Pattern Learning For Delayed Off Time

The sensor will automatically change the delayed off time in response to the occupancy and environmental conditions of the space where it is installed. The sensor analyzes the motion signal properties and will minimize the delayed off time duration when there is frequent motion detection, and lengthen the delayed off time duration when there is weak and infrequent motion detection. In the case of a false-off condition (lights turn off when the room is occupied), the delayed off time duration will immediately be lengthened to prevent further false turn offs.

Occupancy Pattern Learning for Ultrasonic Technology

The sensor learns the occupancy patterns of a space during the course of a day, for a seven day period. At any given time, the sensor will look at the collected data and adjust its ultrasonic sensitivity. The sensor will adjust the sensitivity to make it less likely to turn on during a period of non-occupancy and more likely to turn on during a period of occupancy. This adapting feature is not applicable when the sensor is using PIR functions only.

ADJUSTMENT KNOB AND SWITCH SETTINGS

The two tables (below and in the next column) and the "Minimum and Default Settings" illustration define the settings of the adjustment knobs and the DIP switches.

Adjustment Knob Settings

KNOB COLOR	SYMBOL	FUNCTION	KNOB SETTING	DEFAULT SETTING
Red		Sets the infrared range	Range setting Full CCW = min. (OFF) Full CW = max.	75%
Black		Delayed- Off Time	Full CCW = min. (30 sec.) Full CW = max. (30 min.)	50% (10 min)
Blue		Ambient Light Override (Gray wire only)	Full CCW - Lights stay OFF Full CW - Lights always turn ON (NO ambient light override) Range - 100-3000 LUX	100%

DIP Switch Settings

SWITCH	BANK A	SWITCH SETTINGS	
		OFF	ON
A1	N/A	N/A	N/A
A2	N/A	N/A	N/A
A3	Manual Mode	Auto Adapting Enabled	Auto Adapting Disabled
A4	Walk-Through Disable	Walk-Through Enabled	Walk-Through Disabled
Bank B			
B1	Override to ON	Auto Mode	Lights Forced ON
B2	Override to OFF	Auto Mode	Lights Forced OFF
B3	Test Mode	OFF → ON → OFF	Enter/Exit Test Mode
B4	LEDs Disable	LEDs Enabled	LEDs Disabled

Minimum and Default Settings

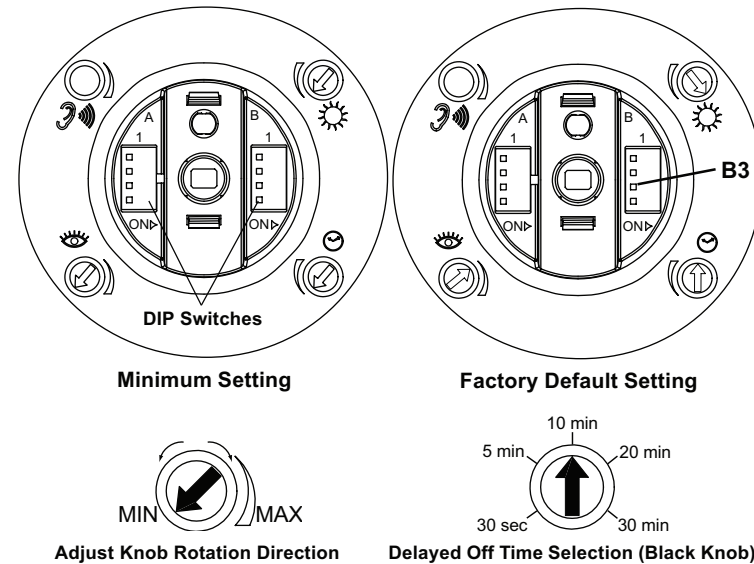

TEST MODE

Set the delayed-off time to six seconds for performing a walk test. While the sensor is in test mode, the LEDs will flash amber once a second.

- ENSURE POWER IS ON.**
- Remove front cover.
- Locate Dip Switch 3 in Bank B (B3). B3 will be in the OFF position from the factory.
- To enter *Test* mode, move switch to ON and back to OFF. The *Test* mode has now been entered with a six second time-out. (Refer to the DIP Switch Settings table.)

NOTE: If B3 is already in the ON position, then *Test* mode can be entered by just moving it to the OFF position.

NOTE: The timer will remain in the six second *Test* mode for 15 minutes, then automatically exit *Test* mode and reset to the delayed-off time setting as defined by the black timer knob.

NOTE: To manually take the timer out of the six second *Test* mode, simply toggle the switch B3 from OFF to ON and back to OFF.

PHOTOCELL (AMBIENT LIGHT OVERRIDE) ADJUSTMENT

In order to use the ambient light override functionality of the sensor, the sensor must be wired to the GLS-SIM (or other compatible interface) using the gray wire instead of the blue wire. This feature allows the user to conserve energy by keeping the controlled lights off when not necessary. The sensor does this by measuring the amount of ambient light in the installed area and keeping the controlled lights off if there is enough ambient light available. To use this feature, the photocell adjustment (blue) knob must be adjusted from the default position. Once this adjustment is made, the controlled lights will only turn on if the ambient light present is less than the setting.

To set the Photocell level (used with the gray wire connection):

NOTE: This setting must be performed when the natural light is low enough to require artificial light.

- Remove the cover from the sensor.
- Make note of the position of the red knob. Rotate the red knob fully CCW and enter the sensor's *Test* mode as described above.
- Rotate the blue knob fully CCW.
- Wait for the lights to turn OFF.
- Rotate the red knob fully CW.
- Slowly rotate the blue knob clockwise until the lights turn ON. This is the correct setting.
- Return the red knob to its original position.
- Replace the cover. Setting is complete.

Field-of-View Ranges - GLS-OIR-C-450

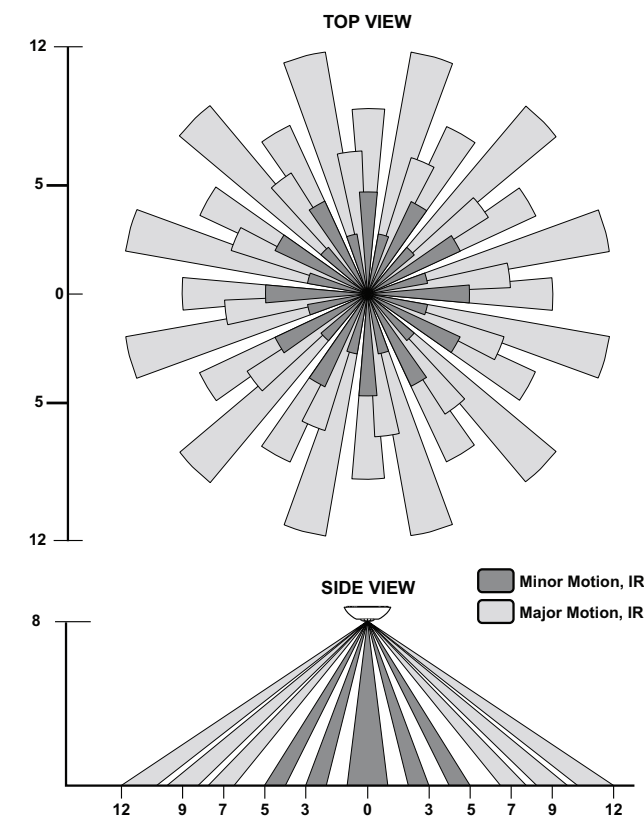

Field-of-View Ranges - GLS-OIR-C-1500

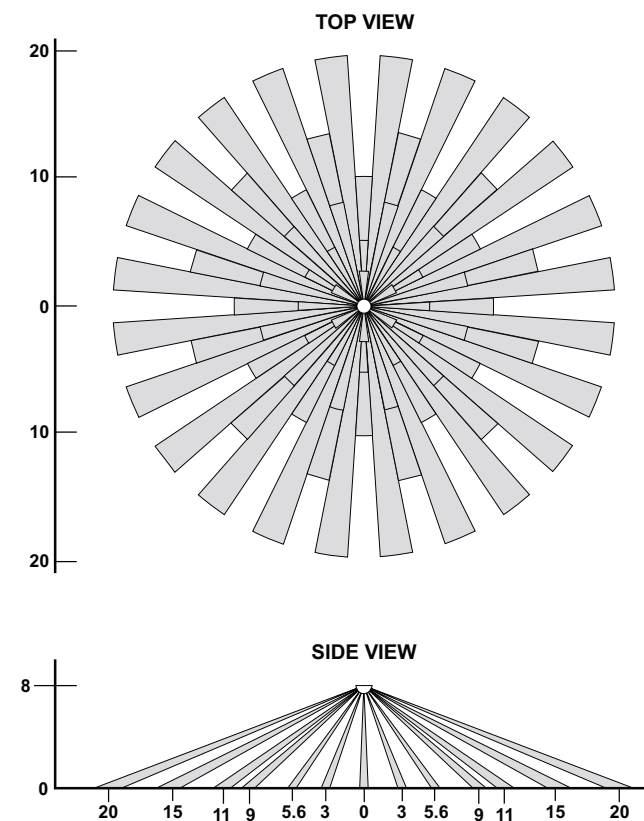

TROUBLESHOOTING

The following table provides corrective action for possible trouble situations. If further assistance is required, please contact a Crestron customer service representative.

NOTE: Operation is ultimately determined by the control system program, and that must be considered when troubleshooting.

TROUBLE	POSSIBLE CAUSE	CORRECTIVE ACTION
Lights do not turn ON.	Circuit breaker or fuse has tripped.	Reset circuit breaker or replace fuse.
	Connections between sensor and GLS-SIM (or other interface device) have been miswired.	Verify that all connections have been made per the wiring diagrams in this document.
	GLS-SIM (or other interface device) set to incorrect Net ID.	Check that the Net ID matches the one expected by the control system (or CLS-C6).
	GLS-SIM DIP switch settings not correct.	Refer to control system and GLS-SIM documentation to see if certain DIP switch settings are required for compatibility with this sensor.
Lights stay ON.	Incorrect programming in control system.	Check control system logic or contact Crestron for assistance.
	Constant motion.	To test, reduce red and green knob by 15%; remove motion source. If no change, move sensor.
	Infrared sensor can "see" into hallway.	To test, put sensor in timer <i>Test</i> mode and walk hallway. If lights continue to come ON, move sensor.
Lights remain ON too long.	Incorrect programming in control system.	Check control system logic or contact Crestron for assistance.
	Timer setting too high.	To test, check switch settings. Typical setting is 10 minutes.

Return and Warranty Policies

Merchandise Returns / Repair Service

- No merchandise may be returned for credit, exchange or service without prior authorization from CRESTRON. To obtain warranty service for CRESTRON products, contact an authorized CRESTRON dealer. Only authorized CRESTRON dealers may contact the factory and request an RMA (Return Merchandise Authorization) number. Enclose a note specifying the nature of the problem, name and phone number of contact person, RMA number and return address.
- Products may be returned for credit, exchange or service with a CRESTRON Return Merchandise Authorization (RMA) number. Authorized returns must be shipped freight prepaid to CRESTRON, 6 Volvo Drive, Rockleigh, N.J. or its authorized subsidiaries, with RMA number clearly marked on the outside of all cartons. Shipments arriving freight collect or without an RMA number shall be subject to refusal. CRESTRON reserves the right in its sole and absolute discretion to charge a 15% restocking fee plus shipping costs on any products returned with an RMA.
- Return freight charges following repair of items under warranty shall be paid by CRESTRON, shipping by standard ground carrier. In the event repairs are found to be non-warranty, return freight costs shall be paid by the purchaser.

CRESTRON Limited Warranty

CRESTRON ELECTRONICS, Inc. warrants its products to be free from manufacturing defects in materials and workmanship under normal use for a period of three (3) years from the date of purchase from CRESTRON, with the following exceptions: disk drives and any other moving or rotating mechanical parts, pan/tilt heads and power supplies are covered for a period of one (1) year; touchscreen display and overlay components are covered for 90 days; batteries and incandescent lamps are not covered.

This warranty extends to products purchased directly from CRESTRON or an authorized CRESTRON dealer. Purchasers should inquire of the dealer regarding the nature and extent of the dealer's warranty, if any.

CRESTRON shall not be liable to honor the terms of this warranty if the product has been used in any application other than that for which it was intended or if it has been subjected to misuse, accidental damage, modification or improper installation procedures. Furthermore, this warranty does not cover any product that has had the serial number altered, defaced or removed. This warranty shall be the sole and exclusive remedy to the original purchaser. In no event shall CRESTRON be liable for incidental or consequential damages of any kind (property or economic damages inclusive) arising from the sale or use of this equipment. CRESTRON is not liable for any claim made by a third party or made by the purchaser for a third party. CRESTRON shall, at its option, repair or replace any product found defective, without charge for parts or labor. Repaired or replaced equipment and parts supplied under this warranty shall be covered only by the unexpired portion of the warranty.

Except as expressly set forth in this warranty, CRESTRON makes no other warranties, expressed or implied, nor authorizes any other party to offer any warranty, including any implied warranties of merchantability or fitness for a particular purpose. Any implied warranties that may be imposed by law are limited to the terms of this limited warranty. This warranty statement supersedes all previous warranties.

Trademark Information

All brand names, product names and trademarks are the sole property of their respective owners. Windows is a registered trademark of Microsoft Corporation. Windows95/98/Me/XP/Vista and WindowsNT/2000 are trademarks of Microsoft Corporation.